



# Monitoring Report

## CARBON OFFSET UNIT (CoU) PROJECT



**Title: Title: 42.5 MW Wind Power Project by BPCL in Karnataka**

Version 2.0

Date 29/03/2025

First CoU Issuance Period: 9 years, 1 month, and 5 days.

Date: 26/11/2015 to 31/12/2024



**Monitoring Report (MR)  
CARBON OFFSET UNIT (CoU) PROJECT**

Monitoring Report	
Title of the project activity	<b>42.5 MW Wind Power Project by BPCL in Karnataka</b>
UCR Project Registration Number	464
Version	2.0
Completion date of the MR	29/03/2025
Monitoring period number and duration of this monitoring period	Monitoring Period Number: 1 Duration of this monitoring Period: (first and last days included (26/11/2015 to 31/12/2024)
Project participants	<b>BHORUKA POWER CORPORATION LTD</b>
Host Party	India
Applied methodologies and standardized baselines	ACM0002., Consolidated baseline methodology for grid-connected electricity generation from renewable sources - Version 22.0
Sectoral scopes	01 Energy industries (Renewable/Non-renewable Sources)
Estimated amount of GHG emission reductions for this monitoring period in the registered PCN	<b>2015:</b> 2396 CoUs/yr (2396 tCO <sub>2</sub> eq/yr) <b>2016:</b> 73198 CoUs/yr (73198 tCO <sub>2</sub> eq/yr) <b>2017:</b> 73411 CoUs/yr (73411 tCO <sub>2</sub> eq/yr) <b>2018:</b> 85992 CoUs/yr (85992 tCO <sub>2</sub> eq/yr) <b>2019:</b> 72122 CoUs/yr (72122 tCO <sub>2</sub> eq/yr) <b>2020:</b> 75120 CoUs/yr (75120 tCO <sub>2</sub> eq/yr) <b>2021:</b> 70966 CoUs/yr (70966 tCO <sub>2</sub> eq/yr) <b>2022:</b> 54203 CoUs/yr (54203 tCO <sub>2</sub> eq/yr) <b>2023:</b> 72290 CoUs/yr (72290 tCO <sub>2</sub> eq/yr) <b>2024:</b> 61285 CoUs/yr (61285 tCO <sub>2</sub> eq/yr)
<b>Total:</b>	<b>6,40,983 CoUs ( 6,40,983 tCO<sub>2</sub>eq)</b>

## SECTION A. Description of project activity

### A.1. Purpose and general description of project activity >>

The "BHORUKA POWER CORPORATION LTD 42.5 MW Karnataka" project, located in Yelisirur Village, Gadag District, Karnataka State, India, has been effectively commissioned by Karnataka Power Transmission Corporation Limited (KPTCL). The Chief Electrical Inspector to the Government of Karnataka granted commissioning and interconnection approvals, while the Chief Engineer (T&QC) at KPTCL provided respective permissions.

#### a) Purpose of the project activity and the measures taken for GHG emission reductions >>

The project aims to harness wind energy as a sustainable alternative for generating electricity, thereby reducing the carbon footprint attributable to human activities. By replacing electricity generation from existing and planned fossil fuel-based plants connected to the grid, the project mitigates emissions equivalent to those produced by such plants. The utilization of Wind Energy Converters (WEC) facilitates emission-free electricity production. Below is a summary of the dates on which the installed Wind Turbine Generators were put into operation:

Sr. No.	Make	Turbine No	Capacity	Commissioning Date	Latitude (Degrees North)	Longitude (Degrees East)
1	GE India Industrial Pvt. Ltd	Yelisirur-II T01	1.7 MW	26.11.2015	15.2587	75.58277
2	GE India Industrial Pvt. Ltd	Yelisirur-II T02	1.7 MW	26.11.2015	15.25678	75.5876
3	GE India Industrial Pvt. Ltd	Yelisirur-II T03	1.7 MW	26.11.2015	15.25606	75.59522
4	GE India Industrial Pvt. Ltd	Yelisirur-II T04	1.7 MW	26.11.2015	15.25263	75.59689
5	GE India Industrial Pvt. Ltd	Yelisirur-II T05	1.7 MW	26.11.2015	15.25127	75.59984
6	GE India Industrial Pvt. Ltd	Yelisirur-II T06	1.7 MW	26.11.2015	15.25385	75.61906
7	GE India Industrial Pvt. Ltd	Yelisirur-II T07	1.7 MW	26.11.2015	15.25644	75.61675
8	GE India Industrial Pvt. Ltd	Yelisirur-II T08	1.7 MW	26.11.2015	15.25872	75.60954
9	GE India Industrial Pvt. Ltd	Yelisirur-II T09	1.7 MW	26.11.2015	15.26252	75.60886
10	GE India Industrial Pvt. Ltd	Yelisirur-II T10	1.7 MW	26.11.2015	15.26901	75.61261
11	GE India Industrial Pvt. Ltd	Yelisirur-II T11	1.7 MW	26.11.2015	15.27198	75.6116
12	GE India Industrial Pvt. Ltd	Yelisirur-II T12	1.7 MW	26.11.2015	15.2743	75.61215
13	GE India Industrial Pvt. Ltd	Yelisirur-II T13	1.7 MW	26.11.2015	15.27663	75.61214
14	GE India Industrial Pvt. Ltd	Yelisirur-II T14	1.7 MW	26.11.2015	15.27906	75.61386
15	GE India Industrial Pvt. Ltd	Yelisirur-II T15	1.7 MW	26.11.2015	15.28221	75.61454
16	GE India Industrial	Yelisirur-II	1.7 MW	11.07.2016	15.2805	75.61955

	Pvt. Ltd	T16				
17	GE India Industrial Pvt. Ltd	Yelisirur-II T17	1.7 MW	11.07.2016	15.27656	75.62849
18	GE India Industrial Pvt. Ltd	Yelisirur-II T18	1.7 MW	11.07.2016	15.27151	75.63493
19	GE India Industrial Pvt. Ltd	Yelisirur-II T19	1.7 MW	11.07.2016	15.26717	75.62235
20	GE India Industrial Pvt. Ltd	Yelisirur-II T20	1.7 MW	11.07.2016	15.26233	75.61979
21	GE India Industrial Pvt. Ltd	Yelisirur-II T21	1.7 MW	11.07.2016	15.2683	75.63981
22	GE India Industrial Pvt. Ltd	Yelisirur-II T22	1.7 MW	11.07.2016	15.28266	75.64488
23	GE India Industrial Pvt. Ltd	Yelisirur-II T23	1.7 MW	11.07.2016	15.28769	75.64423
24	GE India Industrial Pvt. Ltd	Yelisirur-II T24	1.7 MW	11.07.2016	15.28346	75.63606
25	GE India Industrial Pvt. Ltd	Yelisirur-II T25	1.7 MW	11.07.2016	15.2792	75.6365

The project generate approximately 7,25,066.35 MWh of electricity, which will be supplied to KPTCL by the project owner under a Power Purchase Agreement. Through the utilization of wind energy, the project plays a role in mitigating greenhouse gas emissions, particularly CO2 equivalents, which would otherwise originate from fossil fuel-powered thermal plants. The CO2 Emission Reduction from the project is **6,40,983 tCO2e** for the monitoring period **26/11/2015 to 31/12/2024**

b) Brief description of the installed technology and equipment>>

The Project activity consists of Electric Wind Energy's GE 1.7 – 103 turbines installed at the Yelisirur site. A procurement of 25 units of these turbines, each with a capacity of 1.7 MW. The primary components of the wind turbines are delineated as follow

- **Rotor:** The rotor, with three adjustable blades, optimizes energy capture in varying wind conditions, enhancing overall efficiency and performance.
- **Gearbox:** Specially designed for high performance and noise reduction, the gearbox ensures smooth operation and longevity of the wind turbine system.
- **Braking Systems:** Blade pitching and mechanical disc brakes provide robust braking control, ensuring safe operation and quick response to varying wind speeds.
- **Generator:** A doubly-fed asynchronous machine with adjustable speed control enhances energy conversion efficiency while maintaining reliability and safety standards.
- **Yaw System:** Grid-fed drives and disc brakes enable precise yaw control, ensuring the turbine maintains alignment with wind direction for optimal energy capture.
- **Nacelle:** Featuring sound insulation and safety controls, the nacelle provides a secure environment for housing control units and emergency systems.

- **Tower:** With a modular design and corrosion protection, the tower ensures structural integrity and longevity, providing stability for the entire turbine system.

c) Relevant dates for the project activity (e.g. construction, commissioning, continued operation periods, etc.)>>

Provide the duration of the crediting period corresponding to the monitoring period covered in this monitoring report.

UCR Project ID or Date of Authorization: **464**

Start Date of Crediting Period: **26/11/2015**

Project Commissioned: **26/11/2015**

d) Total GHG emission reductions achieved or net anthropogenic GHG removals by sinks achieved in this monitoring period>>

The total GHG emission reductions achieved in this monitoring period is as follows:

<b>Summary of the Project Activity and ERs Generated for the Monitoring Period</b>	
Start date of this Monitoring Period	26/11/2015
Carbon credits claimed up to	31/12/2024
Total ERs generated (tCO <sub>2eq</sub> )	<b>640,983 tCO<sub>2eq</sub></b>
Leakage	0

e) Baseline Scenario>>

This section provides details of emission displacement rates/coefficients/factors established by the applicable methodology selected for the project. As per approved consolidated methodology ACM0002, version 22.0, if the project activity is the installation of a new grid connected renewable power plant/unit, the baseline scenario is the following:

**“The baseline scenario is that the electricity delivered to the grid by the project activity would have otherwise been generated by the operation of grid-connected power plants and by the addition of new generation sources into the grid”.**

A.2. Location of project activity>>

Country: India

Village: Yelisirur

District: Gadag

State: Karnataka

Code: 582120

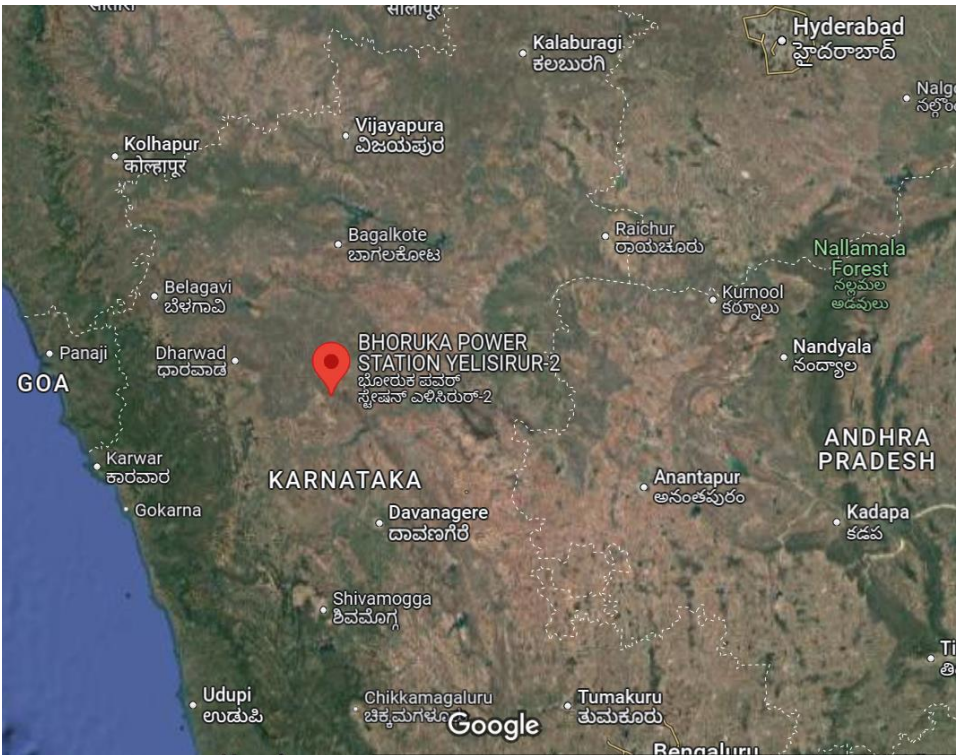
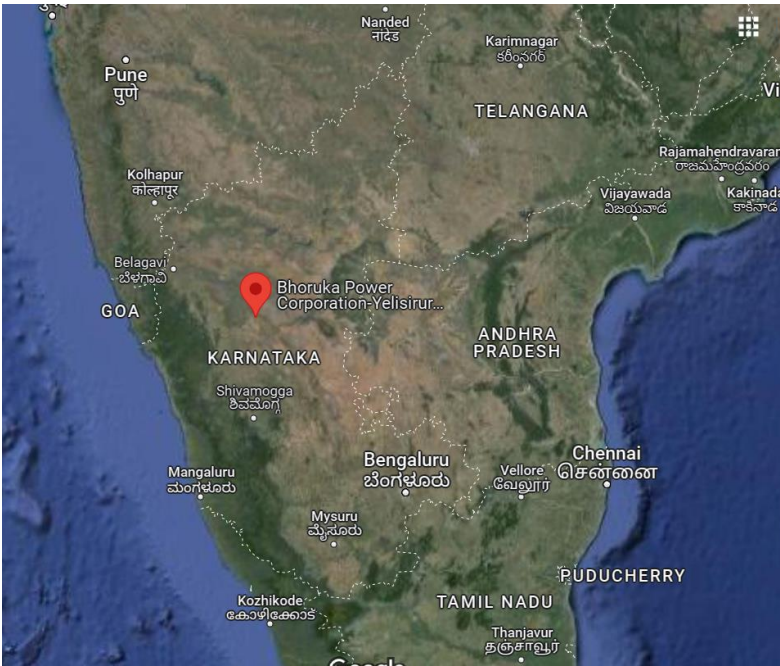

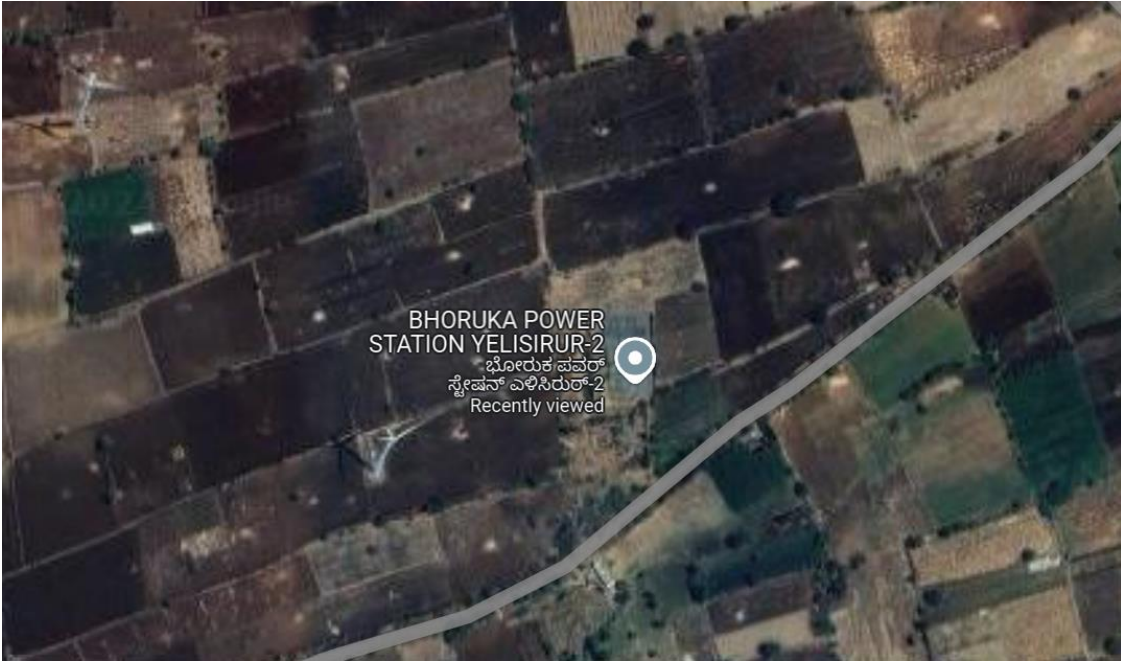

### A.3. Parties and project participants >>

Party (Host)	Participants
India	BHORUKA POWER CORPORATION LTD

### A.4. References to methodologies and standardized baselines >>

**SECTORAL SCOPE** –01 Energy industries (Renewable/Non-renewable sources)

**TYPE** - **Renewable Energy Projects**

**CATEGORY**- ACM0002., Consolidated baseline methodology for grid-connected electricity generation from renewable sources -Version 22.0

### A.5. Crediting period of project activity >>

Start date:26/11/2015

Length of the crediting period corresponding to this monitoring period: (9 years 1 months 5 days.  
26/11/2015-31/12/2024

### A.6. Contact information of responsible persons/entities >>

Contact Person- Lokesh Jain

Email- lokesh.jain@viviidgreen.com

Phone no- 91 89208 56146

Address- Sri Krishna Complex, New Link Road, Opp. Laxmi Industrial Estate, Andheri (West),  
Mumbai - 400053

## SECTION B. Implementation of project activity

### B.1. Description of implemented registered project activity >>

a) Provide information on the implementation status of the project activity during this monitoring period in accordance with UCR PCN>>

The primary objective of the project is to establish and operate a 42.5 MW wind farm in high wind speed regions of Karnataka to generate clean electricity. Bhoruka Power Corporation Ltd serves as the Project Proponent for these wind farms. The project was commissioned on various dates as approved by the relevant authorities in Karnataka. The technology utilized is among the most environmentally friendly options available, as wind power generation does not emit greenhouse gases (GHGs) or other harmful emissions, unlike conventional power plants. The project employs reliable and proven technology to ensure the implementation of a safe and sustainable energy solution.

b) For the description of the installed technology(ies), technical process and equipment, include diagrams, where appropriate>>

The project activity involves the installation of GE 1.7–103 wind turbines by Electric Wind Energy at the Yelisirur site. A total of 25 turbines, each with a capacity of 1.7 MW. These turbines are engineered with advanced aerodynamic design and state-of-the-art technology to maximize energy conversion efficiency. The blades capture wind's kinetic energy, which is then transformed into mechanical energy through the turbine's rotor system. This mechanical energy drives a generator, converting it into clean, renewable electricity. The GE 1.7–103 turbines ensure reliable performance and contribute significantly to reducing greenhouse gas emissions, showcasing a commitment to sustainable energy production.

**The key features of the project equipment are outlined in the table below.**

<b>Technical Data</b>	Model No	GE 1.7– 103, 80m HH
	Make of WEG	M/s. GE India Industrial Pvt. Ltd
	Rotor Diameter	103m
	Cut in wind speed	3.5m/s
	Rated Wind speed	12 m/s (approx.)
	Speed	10-20 rpm
	Hub height	80m
<b>Rotor</b>	Number of blades	3
	Rotor shaft tilt angle	4°
	Rotational direction	Clockwise
	Orientation to the tower	Upwind
<b>Gearbox</b>	Type	Planetary Spur combination
	Rated power	1870Kw
	Rated efficiency	N=96.8%
	Rated Power	1700Kw

<b>Generator/ Transformer</b>	Type	Doubly fed asynchronous generator
	Synchronous speed	1500rpm
	Rated speed	1800rpm
	Rated efficiency	96.10%
	Adjusting Speed	0.5/sec
<b>Meter Details</b>	Meter Type	Electronic Trivector Meter
	Phase Configuration	3-phase, 4-wire type
	Accuracy Class	0.2 (for both meters and transformers)
	Additional Meter	Check Meter (same specification as main)
	Meter Enclosure	Tamper-proof metering box

## **B.2 Do no harm or Impact test of the project activity>>**

There are social, environmental, economic, and technological benefits that contribute to sustainable development.

### **Social Benefits:**

- The project's implementation supports the establishment of vital infrastructure such as road networks within the wind park vicinity, enhancing accessibility and directly benefiting the local community.
- Through the creation of employment opportunities and the bolstering of the local grid managed by the state electricity utility, the project plays a significant role in poverty alleviation and fostering economic growth.
- By harnessing renewable energy sources, the project reduces dependence on imported fossil fuels, thus mitigating price fluctuations and strengthening energy security.

### **Environmental Benefits:**

- Utilizing wind energy instead of burning fossil fuels for electricity generation significantly decreases the emission of harmful pollutants, fostering cleaner air, water, and soil.
- Leveraging wind energy aids in preserving natural resources and minimizing detrimental impacts on the environment, contributing to overall ecological well-being.
- Moreover, harnessing wind energy offers a sustainable alternative to burning fossil fuels, which not only mitigates pollution but also conserves natural habitats and biodiversity, supporting healthier ecosystems and enhancing environmental resilience.





### **Economic Benefits:**

- The project offers employment prospects to both trained and semi-skilled workers within the wind park vicinity, encompassing temporary as well as permanent positions, thereby facilitating local economic advancement.
- Through power generation, the regional grid's performance will be enhanced, leading to increased accessibility and stability for local residents, consequently driving economic and industrial development in the vicinity and creating additional employment opportunities.

### **• Technical Benefits:**

- The utilization of wind energy offers technical advantages such as minimal mechanical complexity and modularity, facilitating easier maintenance and scalability compared to conventional energy systems.
- Increased support for wind energy projects will spur technological companies' R&D efforts, which will lead to the creation of more advanced and efficient gear in the upcoming years.

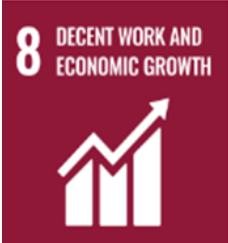
## United Nations Sustainable Development Goals:

SDGs	Contribution
<p>SDG 3: Good Health and Well-being</p> 	<ul style="list-style-type: none"> <li>- Decreases air pollution from fossil fuel emissions, leading to better air quality and fewer respiratory illnesses.</li> <li>- Supports improved health outcomes by enhancing access to healthcare services through job creation and economic development.</li> </ul>
<p>SDG 7: Affordable and Clean Energy</p> 	<ul style="list-style-type: none"> <li>- Advances SDG 7 by generating renewable energy, offering a cleaner alternative to fossil fuels.</li> <li>- Reduces reliance on imported fossil fuels, helping stabilize energy prices and improve regional energy security.</li> </ul>
<p>SDG 8: Decent Work and Economic Growth</p> 	<ul style="list-style-type: none"> <li>- Creates short-term and long-term employment opportunities in construction, maintenance, and administrative roles.</li> <li>- Encourages local economic growth by reinforcing regional grid infrastructure, which boosts industrial activities and job creation.</li> </ul>
<p>SDG 13: Climate Action</p> 	<ul style="list-style-type: none"> <li>- Lowers greenhouse gas emissions by replacing fossil fuel-based electricity, supporting SDG 13.</li> <li>- Cuts approximately 6,40,983 tons of CO2 emissions each year, significantly mitigating climate change through renewable energy solutions.</li> </ul>

### B.3. Baseline Emissions>>

The baseline scenario identified during the PCN stage of the project activity entails the following:

- Grid:

If the project activity had not been implemented, an equivalent amount of electricity would have been generated from fossil fuel-based power plants and supplied to the southern regional grid, which is part of the unified Indian Grid system. This is because the national grid primarily relies on electricity generated from fossil fuel-based power plants. Therefore, the baseline scenario of the project activity corresponds to the grid-based electricity system, which aligns with the pre-project scenario.

The Schematic diagram showing the baseline scenario:

#### Baseline Scenario:

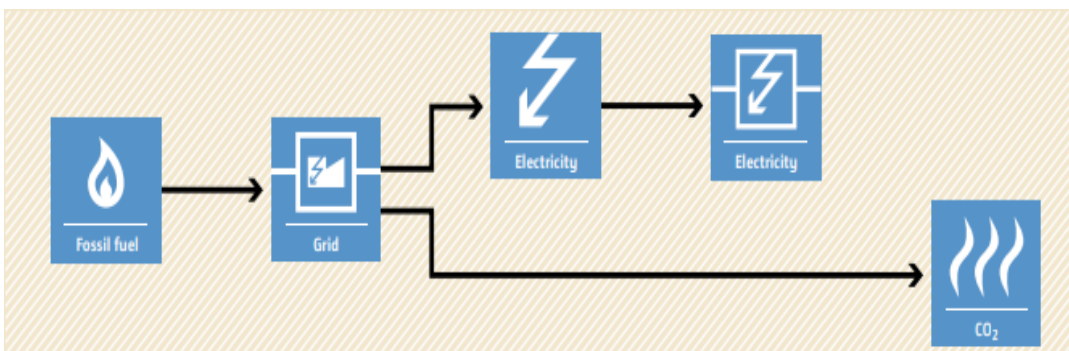

#### Project Scenario:

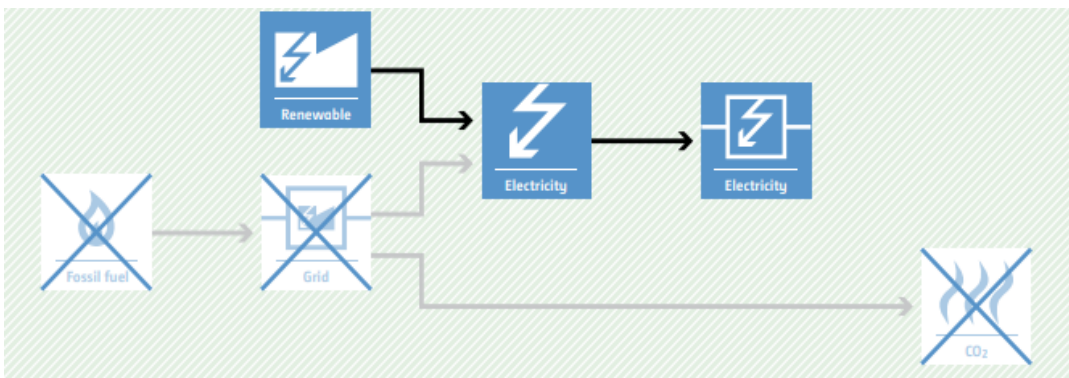

### B.4. Debundling>>

This project is not a debundled component of a larger registered carbon offset project activity.

## SECTION C. Application of methodologies and standardized baselines

### C.1. References to methodologies and standardized baselines >>

**SECTORAL SCOPE** –01 Energy industries (Renewable/Non-renewable sources)

**TYPE** - Renewable Energy Projects

**CATEGORY**- ACM0002., Consolidated baseline methodology for grid-connected electricity generation from renewable sources -Version 22.0

### C.2. Applicability of methodologies and standardized baselines >>

Applicability Criteria.	Applicability status
<p>1) This methodology is applicable to grid-connected renewable energy power generation project activities that:</p> <ul style="list-style-type: none"> <li>(a) Install a Greenfield power plant;</li> <li>(b) Involve a capacity addition to (an) existing plant(s);</li> <li>(c) Involve a retrofit of (an) existing operating plant(s)/unit(s);</li> <li>(d) Involve a rehabilitation of (an) existing plant(s)/unit(s), or</li> <li>(e) Involve a replacement of (an) existing plant(s)/unit(s).</li> <li>(f) Install a Greenfield power plant together with a grid-connected Greenfield pumped storage power plant. The greenfield power plant may be directly connected to the PSP or connected to the PSP through the grid.</li> </ul>	<p>The proposed project involves establishing a new grid-connected renewable wind power plant, confirming to the specified criteria.</p>
<p>2) In case the project activity involves the integration of a BESS, the methodology is applicable to grid-connected renewable energy power generation project activities that:</p> <ul style="list-style-type: none"> <li>(a) Integrate BESS with a Greenfield power plant;</li> <li>(b) Integrate a BESS together with implementing a capacity addition to (an) existing solar photovoltaic or wind power plant(s)/unit(s);</li> <li>(c) Integrate a BESS to (an) existing solar photovoltaic or wind power plant(s)/unit(s) without implementing any other changes to the existing plant(s);</li> <li>(d) Integrate a BESS together with implementing a retrofit of (an) existing solar photovoltaic or wind power plant(s)/unit(s).</li> <li>(e) Integrate a BESS together with a Greenfield power plant that is operating in coordination with a PSP. The BESS is located at site of the greenfield renewable power plant.</li> </ul>	<p>The project entails installing a new grid-connected renewable wind power project without the integration of a Battery Energy Storage System (BESS). Therefore, this condition does not apply to the project activity.</p>
<p>3) The methodology is applicable under the following conditions:</p> <ul style="list-style-type: none"> <li>(a) Hydro power plant/unit with or without reservoir, wind power plant/unit, geothermal power plant/unit, solar power plant/unit, wave power plant/unit or tidal power plant/unit;</li> <li>(b) In the case of capacity additions, retrofits, rehabilitations or replacements (except for wind, solar, wave or tidal power capacity addition projects) the existing plant/unit started commercial operation prior to the start of a minimum historical reference period of five years, used for the calculation of baseline emissions and defined in the baseline emission section, and no capacity expansion, retrofit, or rehabilitation of the plant/unit has been undertaken between the start of this minimum historical reference period and the implementation of the project activity;</li> <li>(c) In case of Greenfield project activities applicable under paragraph 7(a) above, the project participants shall demonstrate that the BESS was an integral part of the design of the renewable energy project activity (e.g., by referring to feasibility studies or investment decision documents);</li> <li>(d) The BESS should be charged with electricity generated from the</li> </ul>	<p>The proposed project involves installing new wind power plants without integrating a Battery Energy Storage System (BESS). Thus, the mentioned criterion does not apply</p>

<p>associated renewable energy power plant(s). Only during exigencies<sup>2</sup> may the BESS be charged with electricity from the grid or a fossil fuel electricity generator. In such cases, the corresponding GHG emissions shall be accounted for as project emissions following the requirements under section 5.4.4 below. The charging using the grid or using fossil fuel electricity generator should not amount to more than 2 per cent of the electricity generated by the project renewable energy plant during a monitoring period. During the time periods (e.g., week(s), months(s)) when the BESS consumes more than 2 per cent of the electricity for charging, the project participant shall not be entitled to issuance of the certified emission reductions for the concerned periods of the monitoring period.</p> <p>(e) In case the project activity involves PSP, the PSP shall utilize the electricity generated from the renewable energy power plant(s) that is operating in coordination with the PSP during pumping mode</p>	
<p>4)In case of hydro power plants, one of the following conditions shall apply:</p> <p>a)The project activity is implemented in an existing single or multiple reservoirs, with no change in the volume of any of reservoirs; or</p> <p>b)The project activity is implemented in an existing single or multiple reservoirs, where the volume of the reservoir(s) is increased and the power density calculated using equation (7) is greater than 4 W/m<sup>2</sup>; or</p> <p>c)The project activity results in new single or multiple reservoirs and the power density calculate equation (7), is greater than 4 W/m<sup>2</sup>.</p> <p>d)The project activity is an integrated hydro power project involving multiple reservoirs, where the power density of any of the reservoirs, calculated using equation (7), is lower than or equal to 4 W/m<sup>2</sup>, all of the following conditions shall apply.</p> <p>(i)The power density calculated using the total installed capacity of the integrated project, as per equation (8), is greater than 4 W/m<sup>2</sup>;</p> <p>(ii) Water flow between reservoirs is not used by any other hydropower unit which is not a part of the project activity;</p> <p>(iii)Installed capacity of the power plant(s) with power density lower than or equal to 4 W/m<sup>2</sup> are:</p> <p>a) Lower than or equal to 15 MW; and</p> <p>b) Less than 10 per cent of the total installed capacity of integrated hydro power project.</p>	<p>The proposed project involves the installation of wind power plants/units. Hence, the mentioned criterion is not applicable.</p>
<p>5)In the case of integrated hydro power projects, project proponent shall:</p> <p>a)Demonstrate that water flow from upstream power plants/units spill directly to the downstream reservoir and that collectively constitute to the generation capacity of the integrated hydro power project; or</p> <p>b)Provide an analysis of the water balance covering the water fed to power units, with all possible combinations of reservoirs and without the construction of reservoirs. The purpose of water balance is to demonstrate the requirement of specific combination of reservoirs constructed under CDM project activity for the optimization of power output. This demonstration has to be carried out in the specific scenario of water availability indifferent seasons to optimize the water flow at the inlet of power units. Therefore this water balance will take into account seasonal flows from river, tributaries (if any), and rainfall for minimum five years prior to implementation of CDM project activity.</p>	<p>The proposed project activity involves the installation of wind power plants/units. Therefore, the mentioned criteria are not applicable.</p>
<p>6) In the case of PSP, the project participants shall demonstrate in the PDD that the project is not using water which would have been used to generate electricity in the baseline.</p>	<p>The proposed project activity involves installing wind power plants/units. Therefore, the specified criteria are not applicable.</p>
<p>7)The methodology is not applicable to:</p> <p>a)Project activities that involve switching from fossil fuels to renewable energy sources at the site of the project activity, since in this case the baseline may be the continued use of fossil fuels at the site;</p> <p>b) Biomass-fired power plants;</p>	<p>The proposed project activity involves installing wind power plants/units. Therefore, the specified criteria are not applicable.</p>

8)In the case of retrofits, rehabilitations, replacements, or capacity additions, this methodology is only applicable if the most plausible baseline scenario, as a result of the identification of baseline scenario, is “the continuation of the current situation, that is to use the power generation equipment that was already in use prior to the implementation of the project activity and undertaking business as usual maintenance	The proposed project activity involves installing wind power plants/units. Therefore, the specified criteria are not applicable.
---	--

### C.3 Applicability of double counting emission reductions >>

To avoid double counting of emission reductions in the project, the following measures are implemented:

- The project can be distinctly identified through its precise location coordinates.
- It is equipped with a dedicated commissioning certificate and connection point.
- Energy meters specifically assigned to the project developer's consumption point are linked with the project.

### C.4. Project boundary, sources and greenhouse gases (GHGs)>>

According to the applied methodology ACM0002, Version 22.0,” The spatial extent of the project boundary includes the project power plant/unit, and all power plants/units connected physically to the electricity system that the CDM project power plant is connected to. Thus, the project boundary includes the Wind Turbine Generators (WTG) and the Indian grid system

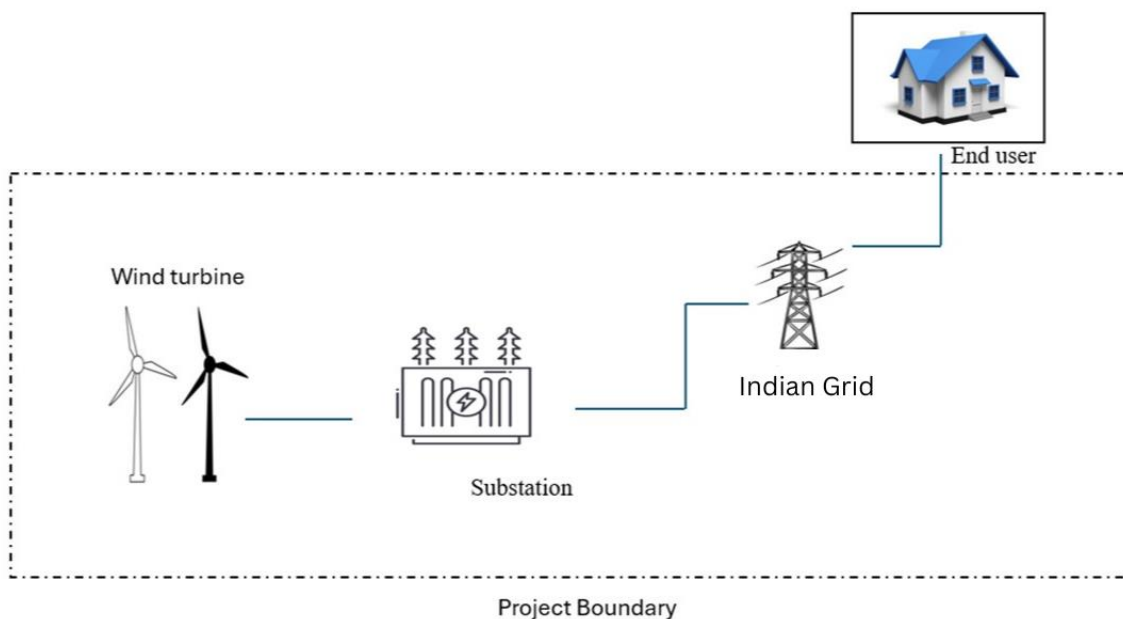

Source	Gas	Included?	Justification/Explanation
CO2 emissions	CO <sub>2</sub>	Yes	Main Emission Source

	from electricity generation in fossil fuel fired power plants that are displaced due to the project activity	CH <sub>4</sub>	No	Minor Emission Source
		N <sub>2</sub> O	No	Minor Emission Source
		Other	No	No other GHG emissions were emitted from the project
Project	Greenfield Wind Power Project Activity	CO <sub>2</sub>	No	The Project activity does not emit CO <sub>2</sub>
		CH <sub>4</sub>	No	Project activity does not emit CH <sub>4</sub>
		N <sub>2</sub> O	No	Project activity does not emit N <sub>2</sub> O
		Other	No	No other emissions are emitted from the project

### C.5. Establishment and description of baseline scenario (UCR Protocol) >>

As per the endorsed consolidated methodology ACM0002, Version 22.0, para 27; when the project activity entails the installation of a new grid-connected renewable power plant/unit, the baseline scenario is described as follows: **"The baseline scenario is electricity delivered to the grid by the project activity that would have otherwise been generated by the operation of grid-connected power plants and by the addition of new generation sources."**

Emission reductions are calculated as follows:

$$ER_y = BE_y - PE_y \quad (\text{Eq. 1})$$

Where,

$ER_y$  = Emissions reductions in year y (t CO<sub>2</sub>)

$BE_y$  = Baseline emissions in year y (t CO<sub>2</sub>)

$PE_y$  = Project emissions in year y (t CO<sub>2</sub>)

#### Baseline Emissions

The baseline emissions as per methodology ACM0002, Version 22.0, para 57; encompass solely the CO<sub>2</sub> emissions stemming from electricity generation in power plants displaced by the project activity. The methodology operates on the assumption that any electricity generation exceeding baseline levels would have originated from established grid-connected power plants and the integration of new grid-connected power plants.

The Baseline emissions ACM0002, Version 22.0 Equation 11 in year y can be calculated as follows:

$$BE_y = EG_{PJ,y} \times EF_{Grid,y} \quad (\text{Eq. 2})$$

Where,

$BE_y$  = Baseline emissions in year y (t CO<sub>2</sub>)

$EGPJ,y$  = Quantity of net electricity generation that is produced and fed into the grid as a result of the implementation of the CDM project activity in year y (MWh)

$EF_{Grid,y}$  = Grid emission factor in year y (t CO<sub>2</sub>/MWh)

<sup>1</sup>A "grid emission factor" denotes the CO<sub>2</sub> emission factor (measured in tCO<sub>2</sub>/MWh) associated with each unit of electricity supplied by the grid. A grid emission factor of 0.9 tCO<sub>2</sub>/MWh is recommended for the years 2013-2023 as a conservative estimate for Indian projects not previously verified under any GHG program. Similarly, for the year 2024, a grid emission factor of 0.757 tCO<sub>2</sub>/MWh is to be applied. These conservative factors are used to calculate emission reductions.

Regarding project emissions, ACM0002 version 22.0 specifies that only emissions related to fossil fuel combustion, emissions from the operation of geothermal power plants due to the release of non-condensable gases, and emissions from water reservoirs of hydroelectric plants should be taken into account. Since the project involves a wind power project, emissions from renewable energy plants are negligible

Hence ( $PE_y = 0$ ).

Leakage, as outlined in ACM0002 version 22.0, para 56 is considered to be zero as there is no transfer of energy-generating equipment in the project activity.

Hence ( $LE_y = 0$ ).

The Year wise emission reduction calculation is given below:

Year	Net Quantity of net electricity generation supplied by the project activity to the grid in year y	Emission Factor	Baseline Emission	Project emissions or actual net GHG removals by sink	Emission reductions or net anthropogenic GHG removals by sinks
	[MWh]	(tCO <sub>2</sub> e/MWh)	(tCO <sub>2</sub> e)	(tCO <sub>2</sub> e)	(tCO <sub>2</sub> e)
		[EF <sub>y</sub> ]	[BE <sub>y</sub> ]= [EG <sub>facility, y</sub> ]* [EF <sub>y</sub> ]	[PE <sub>y</sub> ]	[ER <sub>y</sub> ]=[BE <sub>y</sub> ]-[PE <sub>y</sub> ]- [LE <sub>y</sub> ]
2015	2661.749992	0.9	2395.574993	0	2396
2016	81331.24998	0.9	73198.12499	0	73198
2017	81567.85	0.9	73411.065	0	73411
2018	95546.75	0.9	85992.075	0	85992
2019	80135.25	0.9	72121.725	0	72122
2020	83466.5	0.9	75119.85	0	75120
2021	78851.5	0.9	70966.35	0	70966
2022	60225.75	0.9	54203.175	0	54203
2023	80322.125	0.9	72289.913	0	72290
2024	80957.63	0.757	61284.92591	0	61285
<b>Total</b>	<b>7,25,066.35</b>		<b>640982.7784</b>		<b>640983</b>

<sup>1</sup> [UCRCoUStandardAug2022updatedVer6\\_090822220127104470.pdf \(rackcdn.com\)](https://www.rackcdn.com/UCRCoUStandardAug2022updatedVer6_090822220127104470.pdf)

[UCR CoU Standard Update: 2024 Vintage UCR Indian Grid Emission Factor Announced | by Universal Carbon Registry | Jan, 2025 | Medium](#)

## C.6. Prior History>>

The project activity has not applied to any other GHG program for generation or issuance of carbon offsets or credits for the said crediting period.

## C.7. Monitoring period number and duration>>

Issuance Period	:9 years 1 months 5 days.
Crediting Period	:26/11/2015 to 31/12/2024
Monitoring Period	:26/11/2015 to 31/12/2024

## C.8. Changes to start date of crediting period >>

There is no change in the start date of crediting period.

## C.9. Permanent changes from PCN monitoring plan, applied methodology or applied standardized baseline >>

There are no permanent changes from the registered PCN monitoring plan and applied methodology.

## C.10. Monitoring plan>>

### Data and Parameters available at validation (ex-ante values):

Data/Parameter	EFGGrid.y
Data unit	tCO2 /MWh
Description	A "grid emission factor" denotes the CO2 emission factor (measured in tCO2/MWh) associated with each unit of electricity supplied by the grid. A grid emission factor of 0.9 tCO2/MWh is recommended for the years 2013-2023 as a conservative estimate for Indian projects not previously verified under any GHG program. Similarly, for the year 2024, a grid emission factor of 0.757 tCO2/MWh is to be applied. These conservative factors are used to calculate emission reductions.
Source of data Value(s) applied	<a href="#">UCRCoUStandardAug2022updatedVer6_090822220127104470.pdf (rackcdn.com)</a> <a href="#">UCR CoU Standard Update: 2024 Vintage UCR Indian Grid Emission Factor Announced   by Universal Carbon Registry   Jan, 2025   Medium</a>
Measurement methods and procedures	-
Monitoring frequency	Ex-ante fixed parameter
Purpose of data	For the calculation of Emission Factor of the grid

## Data and Parameters to be monitored

Data / Parameter:	EG <sub>Pj,y</sub>
Data unit:	MWh
Description:	Net electricity supplied to the indian grid facility by the project activity.
Source of data:	Joint Meter Reading Report
Measurement procedures (if any):	<p>- All the cluster meters and sub-station meters (main &amp; check meters) are electronic and two-way (bi-directional) meters that measure both export and import of electricity and provide net electricity exported to the grid.</p> <p>-All the cluster meters and sub-station meters (main &amp; check meters) measure the electricity (export &amp; Import) on continuous basis and are recorded by state utility on monthly basis.</p> <p>Data Type: Measured  Monitoring equipment: Energy Meters are used for monitoring  Calibration frequency: once in five years (as per CEA Indian provision)  Cross checking: Quantity of net electricity supplied to or consumed at PP's facility will be cross-checked from the monthly bills or invoices raised.</p> <p>The Net electricity supplied to the grid will be calculated by the values of Electricity export to the grid.The Net electricity is recorded as follows:  Thus, <math>EG_{Pj,y} = EG_{Net,Export}</math></p>
Value Applied	7,25,066.35 MWh
Monitoring frequency:	<p>Monthly</p> <p>The net energy exported to the grid is measured every month using calibrated energy meter by the State Electricity Board authorities in the presence of the project implementer or its representatives. The meter/s shall be jointly inspected and sealed by authorised representatives of the company and the state utility. Measuring procedure: Will be measured by an export-import energy meter. The net electricity exported by the project plant would either be directly sourced as a measured parameter or be calculated by deducting the amount of imported electricity from the total amount of exported electricity.</p>
QA/QC procedures:	Continuous monitoring, hourly measurement monthly recording. Tri-vector (TVM)/ABT energy meters with accuracy class 0.2s.
Purpose of data	- For baseline emission calculations

### Appendix> Meter Details

Old meter	New Meter	Replacement date	Make	Accuracy Class
14197015 (Main Meter)	23002754 (Main Meter)	29/08/2023	L & T	0.2
14194444 (Check Meter)	23002791 (Check Meter)	29/08/2023	L & T	0.2

### Appendix 1<Calibration details>

Location	Commissioning Date	Calibration date	Calibration validity	Calibration delay
Karnataka	26-11-2015	21-04-2016	20-04-2021	26.11.2015 to 31.04.2016
		20-03-2021	19-03-2026	
		29-08-2023	28-08-2028	

There was a calibration delay during the **November 2015 to April 2016** in monitoring period. To address this, an error factor has been applied to the net export values for the delay period since the meters were not calibrated as per the required frequency. According to VVS guidelines, an error factor of " $\pm 0.2\%$ " should be applied separately to both export and import values. A conservative approach has been adopted. To account for potential errors in both export and import, a cumulative error factor of " $-0.4\%$ " has been applied to the net electricity generation for the delay period.